



powered by  carmanah®

Pure Sine Wave Inverter



GPSW-1000
GPSW-2000
GPSW-3000

Owner's Manual





Table of Contents

| | |
|--------------------------------------|----|
| Introduction | 2 |
| Specifications | 3 |
| Name and Main Function | 6 |
| Installation | 10 |
| Operation | 13 |
| Operating Limits | 17 |
| Troubleshooting | 18 |
| Maintenance | 19 |
| Disclaimer of Liability and Warranty | 19 |

1.0 Introduction

The Go Power! Sine Wave series models are used in a wide range of applications including remote homes, RVs, sailboats, and powerboats. It will operate most televisions and VCRs, personal computers, small appliances, and tools such as drills, sanders, grinders, mixers and blenders. The inverter must have a greater power rating than the load it provides power to. To get the most out of the power inverter, it must be installed and used properly. Please read the instructions in this manual before installing and using this model.



2.0 Specifications

2.1 GPSW-3000 W Inverter

| SPECIFICATIONS | GPSW-3000 (12V) | GPSW-3000 (24V) |
|----------------------------------|--|-----------------|
| Continuous Output Power | 3000 W | |
| Surge Rating | 6000 W | |
| Output Waveform | Pure Sine Wave <3% THD | |
| Output Voltage \pm 5% | 115 VAC RMS | |
| Input Voltage | 10.5 – 15 VDC | 21.0-30.0 |
| Efficiency | 85-95% | |
| No Load Current Draw / Powersave | 2.0A / 0.55A | 1.6A / 0.35A |
| Protection | Overload, Short Circuit, Reverse Polarity (Fuse), Over/Under Input Voltage, Over Temperature | |
| Low Battery Alarm \pm 2% | 10.7 V | 21.4 V |
| Low Battery Shut-Down \pm 2% | 10.3 V | 20.6 V |
| Operating Temperature Range | 0 - 40°C / 32°F - 104°F | |
| Storage Temperature Range | -30°C - 70°C / -22°F - 158°F | |
| Cooling | Thermostatically Controlled Fan | |
| AC Receptacle | Dual GFCI | |
| Remote Port Option | Yes | |
| Dimensions (L x W x H) in mm | 452 x 208 x 6.5 | |
| Dimensions (L x W x H) in inches | 17.8 x 8.2 x 6.5 | |
| Weight | 9.8 kg / 22 lbs | |
| Warranty | 2 Years | |
| Inverter Install Kits | GP-DC-KIT5 | GP-DC-KIT3 |
| UPC | 8-39085-00070-0 | 8-39085-00071-7 |





2.2 GPSW-2000 W Inverter

| SPECIFICATIONS | GPSW-2000 (12V) | GPSW-2000 (24V) |
|----------------------------------|--|-----------------|
| Continuous Output Power | 2000 W | |
| Surge Rating | 4000 W | |
| Output Waveform | Pure Sine Wave <3% THD | |
| Output Voltage \pm 5% | 115 VAC RMS | |
| Input Voltage | 10.5 – 15 VDC | 21.0-30.0 |
| Efficiency | 85-92% | |
| No Load Current Draw / Powersave | 2.8A / 0.6A | 1.5A / 0.3A |
| Protection | Overload, Short Circuit, Reverse Polarity (Fuse), Over/Under Input Voltage, Over Temperature | |
| Low Battery Alarm \pm 2% | 10.7 V | 21.4 V |
| Low Battery Shut-Down \pm 2% | 10.3 V | 20.6 V |
| Operating Temperature Range | 0 - 40°C / 32°F - 104°F | |
| Storage Temperature Range | -30°C - 70°C / -22°F - 158°F | |
| Cooling | Thermostatically Controlled Fan | |
| AC Receptacle | Dual GFCI | |
| Remote Port Option | Yes | |
| Dimensions (L x W x H) in mm | 422 x 208 x 166 | |
| Dimensions (L x W x H) in inches | 16.6 x 8.2 x 6.5 | |
| Weight | 9.5 kg / 21 lbs | |
| Warranty | 2 Years | |
| Inverter Install Kits | GP-DC-KIT4 | GP-DC-KIT3 |
| UPC | 8-39085-00068-7 | 8-39085-00069-4 |





2.3 GPSW-1000 W Inverter

| SPECIFICATIONS | GPSW-1000 (12V) | GPSW-1000 (24V) |
|----------------------------------|--|-----------------|
| Continuous Output Power | 1000 W | |
| Surge Rating | 2000 W | |
| Output Waveform | Pure Sine Wave <3% THD | |
| Output Voltage \pm 5% | 115 VAC RMS | |
| Input Voltage | 10.5 – 15 VDC | 21.0-30.0 |
| Efficiency | 85-92% | |
| No Load Current Draw / Powersave | 1.4A / 0.25 A | 0.75 A / 0.15 A |
| Protection | Overload, Short Circuit, Reverse Polarity (Fuse), Over/Under Input Voltage, Over Temperature | |
| Low Battery Alarm \pm 2% | 10.7 V | 21.4 V |
| Low Battery Shut-Down \pm 2% | 10.3 V | 20.6 V |
| Operating Temperature Range | 0 - 40°C / 32°F - 104°F | |
| Storage Temperature Range | -30°C - 70°C / -22°F - 158°F | |
| Cooling | Thermostatically Controlled Fan | |
| AC Receptacle | Dual GFCI | |
| Remote Port Option | Yes | |
| Dimensions (L x W x H) in mm | 383 x 182 x 89 | |
| Dimensions (L x W x H) in inches | 15.1 x 7.2 x 3.5 | |
| Weight | 4.0 kg / 8.8 lbs | |
| Warranty | 2 Years | |
| Inverter Install Kits | GP-DC-KIT2 | |
| UPC | 8-39085-00067-0 | 8-39085-00136-3 |





3. Name and Main Function

3.1 Front view (GPSW3000 and GPSW2000)

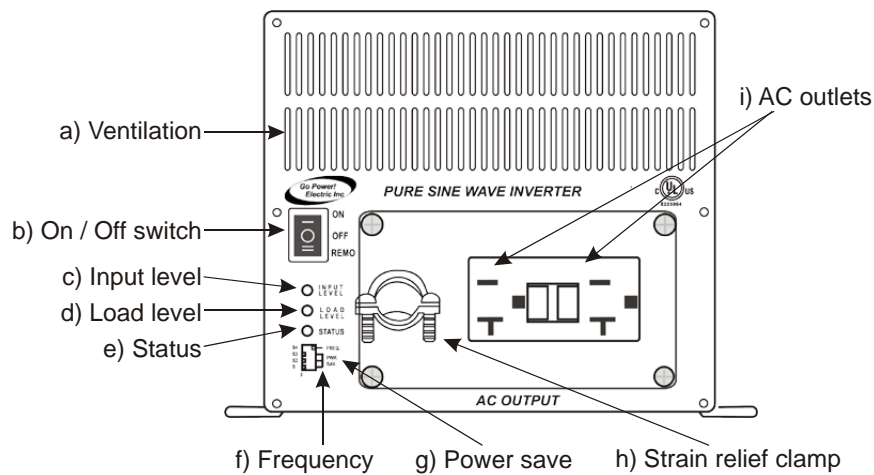

- a. Ventilation Ports:
Do not obstruct, allow at least one inch for airflow.
- b. ON / OFF switch:
Power ON/OFF switch, leave in the OFF position during installation.
Leave in REMOTE position when using optional remote.
- c. Input Level:
Displays input voltage. Green indicates normal battery level, yellow indicates mid to low battery level and red indicates under voltage.
- d. Load Level:
Displays AC load watts. Green indicates normal operation; yellow indicates mid to high operation and red indicates overload levels.
- e. Status Level:
The LED display indicates the power status of the inverter; see section 0 5.0 **Operation** for more information.

| | |
|-------------------------|-----------------------------------|
| Solid Green: | AC power OK |
| Flashing Green | Power Saving Active |
| Fast Red Blink: | Over voltage protection (OVP) |
| Slow Red Blink: | Under voltage protection (UVP) |
| Intermittent Red Blink: | Over temperature protection (OTP) |
| Solid Red: | Overload protection (OLP) |



- f. Frequency:
Typical North American setting is 60 Hz. Set dip switch S4 to “0” for 50 Hz and “1” for 60 Hz.
- g. Power Save:
Puts inverter to sleep until a load is present.
- h. Strain Relief Clamp:
Provides strain relief for Hard Wire AC Output option.
- i. AC Outlet:
Ground Fault Protected (GFCI) Outlet sockets available: North America.

3.1.2 Rearview (GPSW3000 and GPSW2000)

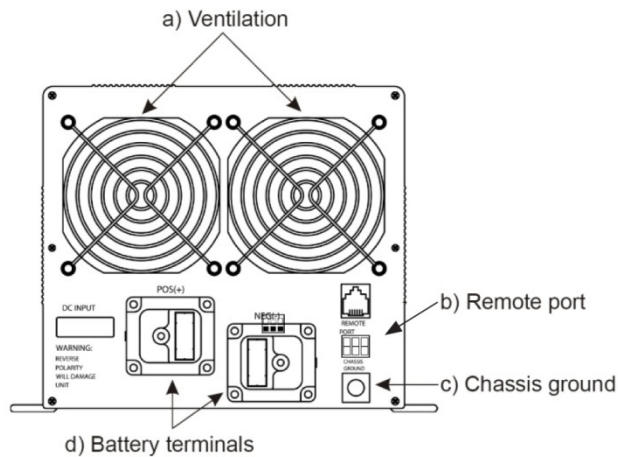

Operation of the inverter without a proper ground connection may result in an electrical safety hazard.

- a. Ventilation port:
Do not obstruct, allow at least one inch for airflow.
- b. Remote Port:
Allows the customer to use any 2 wire switch to turn the inverter ON and OFF. Ex. Toggle switch or light switch.
- c. Chassis Ground:



Ground to vehicle chassis using # 8 AWG wire.

- d. **Battery terminals:**
Connect to 12/24 V battery or other 12/24 V power source. [+] is positive and [-] is negative. Reverse polarity connection will blow the internal fuse and may damage inverter permanently.

3.2 GPSW-1000

3.2.1 Front View (GPSW-1000)

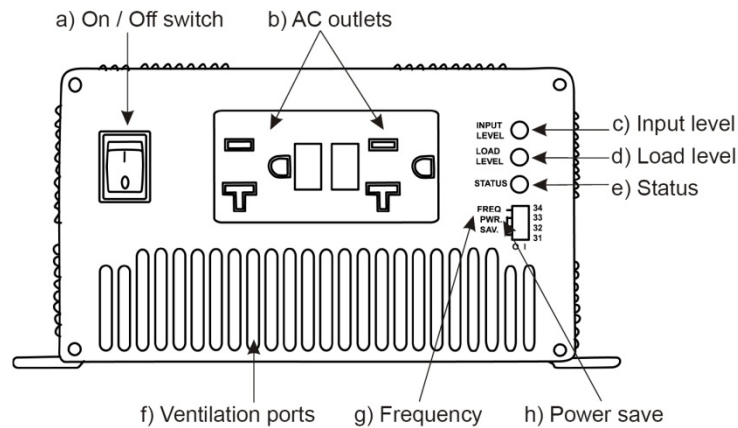

- a. **ON / OFF switch:**
Power ON/OFF switch, leave in the OFF position during installation. Leave in REMOTE position when using optional remote.
- b. **AC Outlet: Ground Fault Protected (GFCI)**
Outlet sockets available: North America
- c. **Input Level:**
Displays input voltage. Green indicates normal battery level, yellow indicates mid to low battery level and red indicates under voltage.
- d. **Load Level:**
Displays AC load watts. Green indicates normal operation; yellow indicates mid to high operation and red indicates overload levels.
- e. **Status Level:**
The LED display indicates the power status of the inverter; see section 5.0 **Operation** for more information.



| | |
|-------------------------|-----------------------------------|
| Solid Green: | AC power OK |
| Flashing Green | Power Saving Active |
| Fast Red Blink: | Over voltage protection (OVP) |
| Slow Red Blink: | Under voltage protection (UVP) |
| Intermittent Red Blink: | Over temperature protection (OTP) |
| Solid Red: | Overload protection (OLP) |

- f. Ventilation Ports:
Do not obstruct, allow at least one inch for airflow
- g. Frequency:
Typical North American setting is 60 Hz. Set dip switch S4 to "0" for 50Hz and "1" for 60 Hz
- h. Power Save:
Puts inverter to sleep until a load is present

3.2.2 Rearview (GPSW-1000)

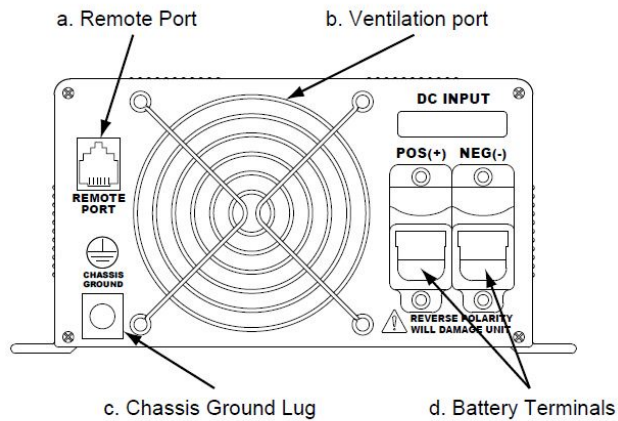

Operation of the inverter without a proper ground connection may result in an electrical safety hazard.

- a. Remote Port:
Allows the customer to use any 2 wire switch to turn the inverter ON and OFF. Ex. Toggle switch or light switch.
- b. Ventilation port:
Do not obstruct, allow at least one inch for airflow.



- c. Chassis Ground:
Ground to vehicle chassis using # 8 AWG wire.
- d. Battery terminals:
Connect to 12/24 V battery or other 12/24 V power source. [+] is positive and [-] is negative. Reverse polarity connection will blow the internal fuse and may damage inverter permanently.

4.0 Installation

4.1 Where to install

The power inverter should be installed in a location that meets the following requirements:



Do not connect this inverter and another AC source (generator or utility power) to the AC wiring or AC loads at the same time. Doing so will destroy the inverter and void the warranty, regardless of the inverter's on or off status. If you are using more than one AC source for the AC wiring or AC loads, it is highly recommended that you install an automatic transfer switch (GP-TS), available from Go-Power.

Dry – Do not allow water to drip or splash on the inverter.

Cool – Ambient air temperature should be between 32 and 104 °F (0 and 40 °C) (the cooler the better).

Ventilated – Allow at least two inches of clearance around the inverter for airflow. Ensure the ventilation openings on the rear and bottom of the unit are not obstructed.

Safe – Do not install the inverter in the same compartment as batteries, or in any compartment capable of igniting flammable liquids such as gasoline.

Inverter should be located within 10 feet (3 m) of the batteries.

4.2 Hook-up and testing



A reverse polarity connection will blow a fuse in the inverter and may permanently damage the inverter. Damage caused by reverse polarity connection is not covered by warranty.

For hook-up, please follow these guidelines:

1. Unpack and inspect your Go Power! Inverter, then check to see that the power switch is in the OFF position. Set up your power output according to Section 10, Configuring your Sine Wave.
2. Insert DC inverter cables (not included) to the power input terminals on the rear panel of the power inverter. The red terminal is positive (+) and



black terminal is negative (-). Connect the cables into the terminals and tighten the terminal screw to clamp the wires securely.

3. Connect the cable from the negative terminal of the inverter to the negative terminal of the battery. Make a secure connection.



Loose connections result in excessive voltage drop and may cause overheated wires and melted insulation.

4. Before proceeding further, carefully check that the cable you have just connected connects from the negative terminal of inverter to the negative terminal of the power source (battery).



You may observe a spark when you make this connection since current may flow to charge capacitors in the power inverter. Do not make this connection in the presence of flammable fumes, as explosion or fire may result.

5. Install inverter fuse (not included) in positive lead. Fuse should be located within 12" of battery. Ensure all connections are tight and secure. (See Section 4.3)
6. Connect the cable from the positive terminal of inverter to the positive terminal of the battery. Make a secure connection.
7. Set the power switch to the ON position. Check the indicators on the front panel of the inverter. The Input Level LED should be green or yellow, depending on the voltage of the power source. If it is not, check your battery bank and the connections to the inverter.
8. Set the power inverter switch to the OFF position. The indicator lights may blink and the internal alarm may sound momentarily. This is normal. Plug the test load into the AC receptacle on the front panel of the inverter. Leave the test load switch OFF.
(For the Hard Wire option, please see Section 4.3).
9. Set the power inverter switch to the ON position and turn the test load on; the inverter should supply power to the load. If you plan to measure the output voltage of the inverter, a true rms meter must be used for accurate readings.



The GFCI outlet of the GPSW3000 is rated for 20 amps or 2200 W. For loads above 20 A or 2200 W please use the Hard Wire option.



4.3 Hard Wire (GPSW3000 and GPSW2000)



Ensure the inverter is turned off if connecting the Hard Wire option.

The GPSW3000 and GPSW2000 AC output may be hard wired into the inverter. Remove the four screws that surround the AC outlet and strain relief clamp to reveal a two-connection terminal strip. Feed a user-supplied power cable through the strain relief clamp, tighten the clamp, and make the connections.

The Black or HOT wire output is labeled “L” and the white or NEUTRAL wire output is labeled “N”. The Green or GROUND wire connection is labeled “FG” or with the standard ground symbol and is located to the right of the terminal strip. The National Electrical Code recommends no less than #10 gauge wire for this application. Seek professional assistance if you are unfamiliar with electrical wiring.

4.4 Cables



Install the inverter fuse into the positive lead. Fuse should be located within 12” of battery. Ensure all connections are tight and secure.

GPSW1000-12V: Please use 10 ft or less of #4 Cable with a 110 Amp fuse.

GPSW1000-24V: Please use 10 ft or less of #8 Cable with a 70 Amp fuse.

A GP-DC Kit 2 suitable for both 12 and 24 V applications is available from Go Power Inc.

GPSW2000-12V: Please use 10 ft or less of 2/0 Cable with a 300 Amp fuse.

GPSW2000-24V: Please use 10 ft or less of #2 Cable with a 200 Amp fuse.

A GP-DC Kit 4 suitable for 12 V and a GP-DC Kit 3 suitable for 24 V applications is available from Go Power Inc.

GPSW3000-12V: Please use 10 ft or less of 4/0 Cable with a 400 Amp fuse.

GPSW3000-24V: Please use 10 ft or less of #2 Cable with a 200 Amp fuse.

A GP-DC Kit 5 suitable for 12 V and a GP-DC Kit 3 suitable for 24 V applications is available from Go Power!TM

4.5 Grounding

The inverter has a chassis ground lug on the rear panel allowing you to connect the chassis of the inverter to ground. The ground terminals in the AC outlets on the front panel of the inverter are internally connected to the chassis ground. If



available, the chassis ground lug should be connected to a grounding point, which will vary depending on where the inverter is installed. In a vehicle, connect the chassis ground to the chassis of the vehicle. In a boat, connect the chassis ground lug to the boat's grounding system. In a fixed location, connect the chassis ground lug to an earth ground.

The neutral (common) conductor of the inverter AC output circuit is connected (bonded) to the chassis ground inside the inverter. Therefore, when the chassis is connected to a ground, the neutral conductor is also grounded. These grounding connections conform to national electrical code requirements which state that separately derived AC sources (such as inverters and generators) have their neutral tied (bonded) to ground in the same way that the neutral conductor from the utility line is tied (bonded) to ground in the AC breaker panel of a non-mobile dwelling.

Important:

As per the national electrical code, electrical panels in mobile applications must not have a bonded neutral. If the inverter is supplying power to equipment or a panel where the neutral and ground are connected (bonded), a ground loop will occur. If a ground loop occurs on inverters with GFCI outlets, the GFCI outlet will trip and output power from the inverter will be cut off. If your GFCI repeatedly needs to be reset, this indicates a ground loop somewhere in your system. In this case, please have a qualified service technician inspect your electrical system or equipment.



The negative DC input of the inverter is connected to the chassis. Do not install the inverter in a positive ground DC system. A positive ground DC system has the positive terminal of the battery connected to the chassis of the vehicle or to the grounding point.

5.0 Operation

To operate the power inverter, turn it on using the ON/OFF switch on the front panel. The power inverter is now ready to deliver AC power to your loads. If you are operating several loads from the power inverter, turn them on separately after the inverter has been turned on. This will ensure that the power inverter does not have to deliver the starting currents for all the loads at once.

5.1 Operating On/Off Switch

The ON/OFF switch turns the control circuit in the power inverter ON and OFF. It does not disconnect power from the power inverter. When the switch is in the OFF position, the power inverter draws no current from the battery. When the switch is in the ON position but with no load, the power inverter draws less than 14.4 W (GPSW1000, GPSW2000 and GPSW3000) from the battery. When in Power Save mode the GPSW1000, GPSW2000 and GPSW3000 will draw



approximately 3.0 W from the battery.

5.2 Input Level (battery voltage) indicator

The GPSW600, GPSW1000, GPSW2000 and GPSW3000 Input Level LED changes colour from green to yellow to red as battery voltage decreases from a resting voltage of 12.7 V - 10.5 V (12 V) or 25.4 V – 21V (24 V). The Input Level LED changes colour from green to yellow to red as battery voltage increases from a resting voltage of 12.7V – 15.0 V (12 V) or 25.4 V – 30.0 V (24 V).

5.3 Load Level Indicator

The Load Level LED Indicator changes color from green to yellow to red as the load is increased. The Load Level LED Indicator will be red at peak wattage or peak load.

The Load Level LED Indicator should be green or yellow for long-term operation. Short-term operation is possible with the load indicator in the red area. If the load rises to dangerous levels, the inverter will protect itself and shut down.

5.5 Status Indicator (GPSW1000, GPSW2000 and GPSW3000)

The status LED indicator will display the operating condition of the inverter. A solid green LED is normal. A flashing green LED indicates the inverter is in power save mode (see Power Saving). A red LED, flashing or otherwise, indicates a fault; see

Table 1: Inverter power states

| State | LED | Description |
|--------------------------|-------------------------|--|
| Over voltage protection | Red LED blinking fast | Over voltage protection indicates that the inverter has shut itself down because its input voltage is over: <ul style="list-style-type: none">• 12 V: 15.0 ~ 16.0 V DC• 24 V: 30.0 ~ 32.0 V DC |
| Under voltage protection | Red LED blinking slowly | Under voltage protection indicates that the inverter has shut itself down because its input voltage is lower than: <ul style="list-style-type: none">• 12 V: 10.0 ~ 10.5 V DC• 24 V: 20.0 ~ 21.0 V DC |



| | | |
|-----------------------------|---------------------------------|---|
| Over temperature protection | Red LED blinking intermittently | Over temperature protection indicates that the inverter has shut itself down because it has become overheated. The inverter may overheat if it has been operated at power levels above its rating or if it has been installed in a location which does not allow it to properly dissipate heat. The inverter automatically restarts once it has cooled down. |
| Overload protection | Red LED solid | Overload protection indicates that the inverter has shut itself down because its output circuit has been short circuited or drastically overloaded. Switch the ON / OFF switch to OFF, correct the fault condition, and then switch the ON / OFF switch back to ON. |

5.6 Power Saving Mode (GPSW1000, GPSW2000, and GPSW3000)

These Inverters include a power saving mode. When power saving is enabled and there is no load present, the inverter will draw approximately three watts of power.

The LED will be solid green if a load is present, and flashing green once every second if there is no load present. If the inverter has just been powered up and power saving is enabled, the LED will remain solid green for approximately 10 seconds and then start to flash if there is no load present. Power saving is enabled and adjusted through dip switches S1, S2, and S3 on the front of the inverter.

Table 2: Dip Switches

| SW1000 | SW2000 and SW3000 | Dip Switch | | |
|---------|-------------------|------------|-----|-----|
| | | S1 | S2 | S3 |
| Disable | Disable | OFF | OFF | OFF |
| 20 W | 40 W | ON | OFF | OFF |
| 40 W | 80 W | OFF | ON | OFF |
| 55 W | 125 W | ON | ON | OFF |
| 75 W | 170 W | OFF | OFF | ON |



| | | | | |
|-------|-------|-----|-----|----|
| 95 W | 210 W | ON | OFF | ON |
| 115 W | 245 W | OFF | ON | ON |
| 135 W | 280 W | ON | ON | ON |

To disable power saving, leave dip switches S1, S2 and S3 in the OFF or 0 position.

5.7 What is Power Saving? (GPSW1000, GPSW2000 and GPSW3000)

Power saving mode enables the inverter to be “on” and waiting for a load, yet draw very little power. When power saving is enabled and the inverter senses a load, it may take one second for the load to become active. This one-second wait will be fine for loads that draw continually, such as televisions and stereos.

However, it may not be suitable for loads that are intermittent such as bread makers, power tools or blenders. Power saving will continually draw a small amount of power from the batteries, so if the inverter will not be in use for longer than a day, it is advisable to turn the inverter off using the on/off switch located on the front of the inverter or remote

5.8 Remote

The GPSW1000, GPSW2000 and GPSW3000 are available with an optional remote (GPSWR-B). The remote will turn the inverter on and off and indicate normal operation or any faults that have caused the inverter to shut down. The remote will show battery voltage and power consumption.

The remote will show if the battery voltage is too high and will sound an alarm if the battery voltage falls too low (Under Voltage). The remote will also sound an alarm if the output power is above the inverter specifications (Overload). The Under Voltage and Overload alarm consists of five single beeps every eight seconds.



6.0 Operating limits

6.1 Power output

Some induction motors used in refrigerators, freezers, pumps, and other motor-operated equipment require very high surge currents to start. The inverter may not be able to start some of these motors even though their rated current draw is within the power rating of inverter. Televisions and computer monitors may surge up to four times their rated power on startup, which may result in the inverter showing an overload fault.

6.2 Input voltage

The inverter operates at the following input voltage ranges:

- **12 V:** 10.5 to 15.0 V
- **24 V:** 21.0 to 30.0 V

The inverter shuts down if the input voltage drops below:

- **12 V:** 10.5 V
- **24 V:** 21.0 V

This protects your battery from being over discharged.

The inverter also shuts down if the input voltage exceeds:

- **12 V:** 15.0 V
- **24 V:** 30.0 V

This protects the inverter against excessive input voltage. Although the inverter incorporates protection against over voltage, it may still be damaged if the input voltage is allowed to exceed:

- **12 V:** 20.0 V
- **24 V:** 35.0 V



7.0 Troubleshooting

7.1 Common problems

Television interference: Operation of the power inverter can interfere with television reception on some channels. If this situation occurs, the following steps may help to alleviate the problem:

- Make sure that the chassis ground lug on the back of the power inverter is solidly connected to the ground system of your vehicle, boat or home.
- Do not operate high power loads with the power inverter while watching television.
- Make sure that the antenna feeding your television provides an adequate "snow free) signal and that you are using good quality cable between the antenna and the TV.
- Move the television as far away from the power inverter as possible.
- Keep the cables between the battery and the power inverter as short as possible and twist them together with about two to three twists per foot. This minimizes radiated interference from the cables.

7.2 Troubleshooting Guide

| Problem and Symptoms | Possible Cause | Solution |
|--|---|--|
| No output voltage, no voltage indication. | Inverter switched off. No power to inverter | Turn inverter ON. Check wiring to inverter. |
| | Internal fuse open | Have qualified service technician check and replace. |
| | Reverse DC polarity | Have qualified service technician check and replace fuse, OBSERVE CORRECT POLARITY. |
| No output voltage, Over Voltage indicator on | High input voltage | Make sure that inverter is connected to 12 V or 24 V battery. Check regulation of charging system. |
| Low battery alarm on all the time. | Poor DC wiring, poor battery condition. | Use proper cable and make solid connections. Use new battery. Reduce load. |
| No output voltage and Under Voltage indicator on | Low input voltage | Recharge battery, check connections and cable. |
| No output voltage, Over Temp | Thermal | Allow inverter to cool off. Reduce load if |



| | | |
|---|--------------------------------|---|
| indicator on, load in excess of: 3000 W : 250 A (12V) or 125 A (24 V); 2000 W: 170A (12V) or 85A (24V); 1000 W: 90 A (12V) or 45 A (24 V); | shutdown | continuous operation required. |
| No output voltage, Over Temp indicator on, load less than: 3000 W : 250 A (12V) or 125 A (24 V); 2000 W: 170 A (12V) or 85 A (24V); 1000 W: 90 A (12 V) or 45 A (24 V); | Thermal shutdown | Improve ventilation, make sure ventilation openings in inverter are not obstructed, reduce ambient temperature. |
| No output voltage, Over Load indicator on. | Short circuit or wiring error. | Check AC wiring for short circuit or improper polarity (hot and neutral reversed). |
| | Very high power load | Remove or reduce load |

8.0 Maintenance

Very little maintenance is required to keep your inverter operating properly. You should clean the exterior of the unit periodically with a damp cloth to prevent accumulation of dust and dirt. At the same time, tighten the screws on the DC input terminals.

9.0 Disclaimer of Liability & Warranty

Go Power!TM provides the following limited 2 year warranty (“Warranty”) coverage as applicable to the purchaser (“Purchaser”) of the Go Power!TM branded product (“Product”) directly from Go Power!TM. The following constitutes the terms and conditions of that limited warranty.

9.1.1 What the Go Power! Warranty Covers and for How Long

Subject to the exclusions and claim procedure set out below, Go Power!TM warrants for a period of 2 years from the date of purchase at the point-of-sale to the original end-user customer (“Sale Date”), that the Go Power!TM Product



provides coverage as follows:

For the period ending 2 years from the Sale Date, Go Power!TM will, at Go Power!TM's discretion, repair or replace the Product which fails to meet the Product Specifications due to a defect in materials or workmanship or apply credit towards the purchase of new Go Power!TM Product.

To exercise this right, the Purchaser shall ship, at its own expense, and return the Product to Go Power! according to the return instructions detailed below, and Go Power!TM will, repair or replace the Product and return it to the Purchaser free of charge, or offer credit towards the purchase of new Product.

Go Power!TM shall be entitled, at its discretion, to use new and/or reconditioned parts in performing warranty repair or providing a replacement Product. Go Power!TM also reserves the right to use parts or Product of original or improved

design in any repair or replacement. All replaced Product and/or any parts removed from repaired Products become the property of Go Power!TM

If Go Power!TM chooses to repair or replace a Product, the above warranty will continue to apply and remain in effect for the balance of the warranty period calculated from the Sale Date (and not the repair or replacement date).

If Go Power!TM chooses to offer a credit towards the purchase of new Product, then the warranty in effect and applicable to the new Product shall apply to the new Product.

9.1.2 What the Go Power! Warranty Does Not Cover

Go Power!TM's Warranty does not provide coverage for the following which are expressly excluded from the above warranty:

- Failure due to normal wear and tear of the Product.
- Failure caused by separate computer software supplied with or associated with a Go Power!TM Product.
- Failure due to fire, water, neglect, improper installation, generalized corrosion, biological infestations, or input voltages that create operating conditions beyond the maximum or minimum listed in the Go Power!TM specifications including lightning strikes.
- Products which have been altered other than by Go Power!TM or authorized by Go Power!TM
- Products that have their original identification (trademark, serial number) markings defaced altered or removed.
- Products utilized as a component part of a product expressly warranted by another manufacturer.
- Operation or storage of the Product outside the specification ranges, and/or alteration or deployment of Go Power!TM Products other than in



accordance with any published or provided user, storage or maintenance requirements.

- Failure that is in any way attributable to the improper use, storage, maintenance, installation or placement of the Go Power!TM Product.
- Failure caused by abuse, misuse, abnormal use, or use in violation of any applicable standard, code or instructions for use in installations, including, but not limited to, those contained in the National Electrical Code, the Standards for Safety of Underwriters Laboratory, Inc., Standards for the International Electrotechnical Commission, Standards for the American National Standards Institute, or the Canadian Standards Association.
- Failure due to acts of God.

9.1.3 Restrictions and Limitations to Go Power!'s Warranty

- This Warranty is not transferable and only applies to the Purchaser.
- Go Power!TM does not warrant the results obtained from the implementation of recommendations made by Go Power!TM or its authorized distributors concerning the use, design or application of Go Power! Products
- The end-user who purchases the Product assumes all responsibility and liability for loss or damage resulting from the handling or use of Go Power!TM Products.
- Go Power!TM's liability on any claim, whether in warranty, contract, negligence, or any other legal theory, for loss, damage or injury arising directly or indirectly from or in relation to the use of the Go Power!TM Product shall in no event exceed the purchase price of the Go Power!TM Product which gave rise to the claim. IN NO EVENT SHALL GO POWER!TM BE LIABLE FOR PUNITIVE, SPECIAL, INCIDENTAL OR CONSEQUENTIAL DAMAGES WHETHER FORSEEABLE OR NOT INCLUDING BUT NOT LIMITED TO LOSS OF PROFITS OR REVENUES, LOSS OF USE OF GOODS, OR LOSS OF BARGAIN.
- The Warranty set out above is the sole warranty granted by Go Power!TM with respect to the Product. No oral understanding, representations or warranties shall be of any effect and Go Power!TM makes no further warranties, express or implied concerning the Go Power!TM Products other than the Warranty set out above. The Buyer, where permitted by applicable law, hereby expressly waives any statutory or implied warranty that the Go Power!TM Product shall be merchantable or fit for a particular purpose.

9.2 Warranty Return Procedure

Visit www.gpelectric.com to read the "frequently asked questions" section of our website to troubleshoot the problem. If trouble persists:



1. Call your Go Power!™ Technical Support team (1-866-247-6527).
2. Return defective product to place of purchase.

9.2.1 End Users

Contact your sales representative or Dealer and discuss the problem. Often the sales representative can troubleshoot common scenarios. If applicable, warranty will be handled between the End User and the Dealer. Go Power!™ will only accept returned items from an End User as a last resort. If you are unable to contact the Dealer, or the Dealer refuses to provide service, please contact Go Power!™ directly.

9.2.2 Dealers

Dealers will handle warranty either through their supplier or Go Power!™ if they qualify as a Purchaser.

9.2.3 Units bought directly from Go Power!

The Purchaser will return the product, freight prepaid, to Go Power!™. You must obtain a Return Material Authorization (RMA) number from Go Power!™ before returning a product. The RMA number MUST be clearly indicated on the outside of the box.

Items received without an RMA number will be refused.

9.2.3 Additional Information

Unless approved by Go Power!™ management, all product shipped collect to Go Power!™ will be refused.

Test items or items that are not under warranty, or units that are not defective, will be charged a minimum bench charge of (\$50.00 US) plus taxes and shipping.

A 15% restocking charge will be applied on goods returned and accepted as "new" stock.

9.4 Out of Warranty Items

Go Power!™ electronic products are non-repairable, Go Power!! does not perform repairs on its products nor does it contract out those repairs to a third party. Go Power!™ does not supply schematics or replacement parts for any of its electronic products.





© 2011 GO POWER!™ By Carmanah Technologies
www.gpelectric.com

MOBI_MAN_GPSW-600-1000-2000-3000_vE_Dec2011